

Lift Technologies Introduces Opti Vis Quad Masts

Improved Visibility
Streamlined Hose Routing
24/7 Reliable Field Proven Performance



From the Leader in Material Handling Front End Solutions



Lift-Tek Opti Vis Quad Masts

The new view is only part of the story

INTERNAL DRAIN BACK CYLINDERS

- Main lift and free lift
- Relieves pressure build up
- Consistent cylinder cycles under varying loads and lift heights

30% VISIBILITY IMPROVEMENT WITH DIHR AND 16% WITH SIHR

- Better view of fork tips
- Reduces product damage
- More productive operators

SLACK CHAIN VALVE

- Combination slack chain (SCV) and lowering control valve
- SCV eliminates shock loads on hoses and chains
- SCV required in cold storage and freezer applications below +20°F
- Also available as an option for other applications

CLEAN, SIMPLE HOSE AND CHAIN ROUTING

- Increased hose life with fewer turns and a larger diameter sheaves
- Hoses and chains are routed over one another rather than side by side providing increased visibility

RIGIDITY AT HIGH LIFT HEIGHTS REDUCES DEFLECTION

- Field proven mast rail design
- Reliable structure and components
- Attachment ready

32% VISIBILITY IMPROVEMENT WITH LIFT-TEK INTEGRAL SIDESHIFTER

- Clear view through the integral sideshifter for picking and placing loads

- Opti Vis Quad Masts are available in 3,500, 4,500 and 5,500 lb. capacities
- Incremental lift heights are available
- Available with a variety of options

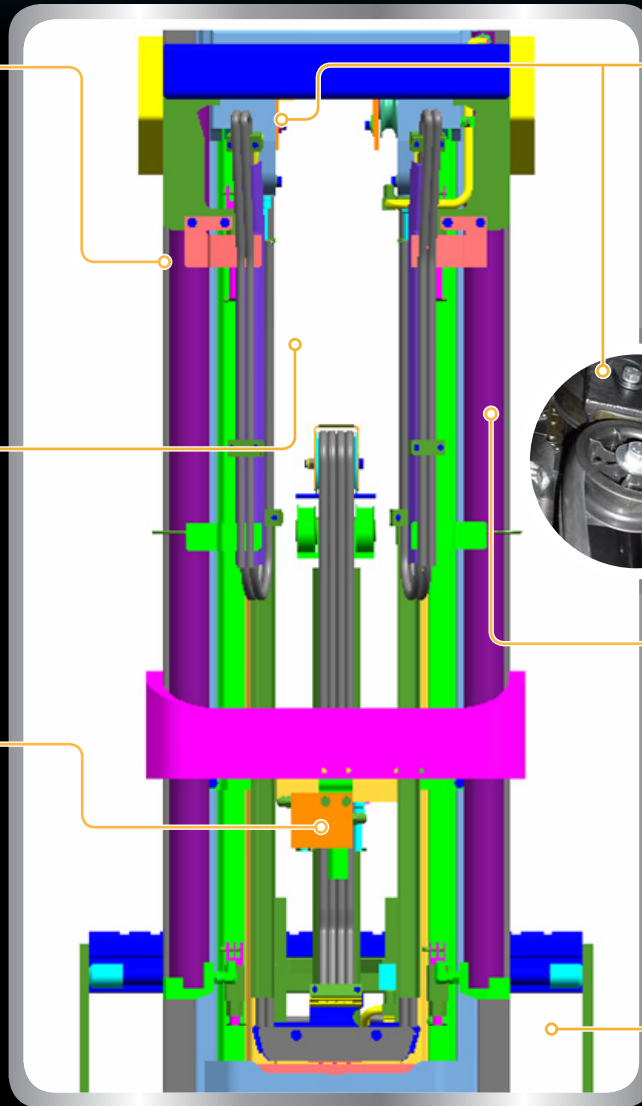

LIFT-TEK

Lift Technologies, Inc.

7040 South Highway 11
Westminster, SC 29693
Tel: (864) 647-1119

A division of



www.lift-tekelecar.com