

# Installation Instructions

## 35D & 45D Quad Roller Masts

### Introduction

This manual provides the installation instructions and adjustment procedures for Lift Tek 35D & 45D Quad roller masts.

These masts provide exceptional visibility for the lift truck driver. The mast carriage and upright channels are all roller mounted which provides smooth operation and long service life.

In any communication about the mast refer to the mast serial number stamped on the nameplate. If the nameplate is missing, these numbers are also stamped on the left-hand side upper cheekplate. See Figure 1.

### Truck System Requirements

To achieve the maximum lifting capacity of the mast, the truck relief valve should be set to relieve at the pressure indicated in the chart below. This chart also indicates the hose and fitting size to use between the truck control valve and mast valve.

Cascade Quad Mast	Relief Pressure	Hose Size	Fitting * Size
35D & 45D	2600 psi	No. 8 min.	No. 8 min. 13/32 in. Orifice

\*Valve inlet port is 3/4 in. SAE O-ring. See Figure 2.



**WARNING:** For proper truck stability or to prevent interference, tilt restriction may be required. **NOTE:** To achieve the proper tilt restriction, contact the truck manufacturer or your truck service manual..

**IMPORTANT:** Lift Tek masts are compatible with SAE 10W petroleum base oil per Mil. Spec. MIL-0-5606 or MIL-0-2104B only. Use of synthetic or aqueous base hydraulic oil is not recommended. If fire resistant hydraulic oil must be used, contact Lift Tek.

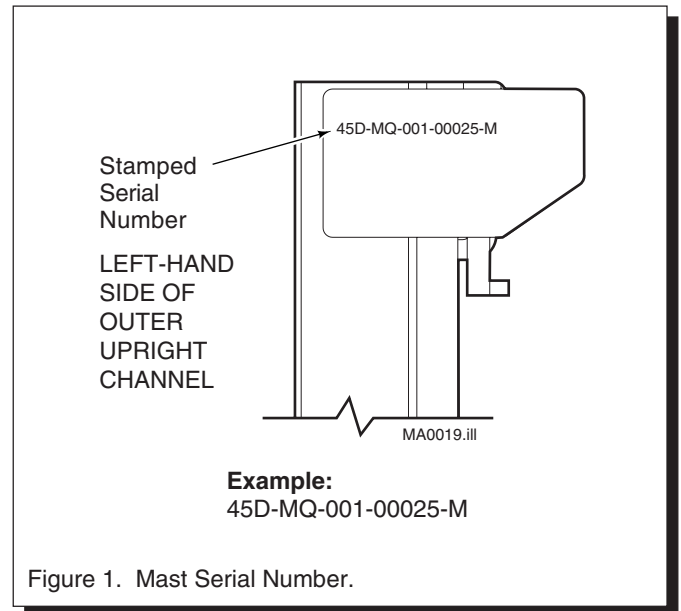

Figure 1. Mast Serial Number.

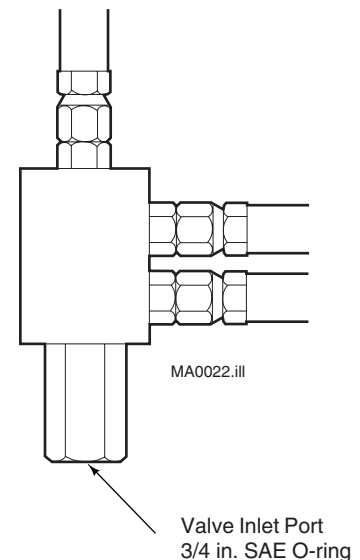

Figure 2. Valve Inlet Port.

Part No. 208813-R2

For Technical Support . . . To Order Parts . . .

Call: 1-888-946-3330

OR

Write: Lift Technologies, 7040 South Highway 11, Westminster, S.C. 29693



## Mast Installation

- 1 Raise and block the front end of the truck up 1 ft. (30 cm) per ANSI B56.1 or drive the truck over a service pit.
- 2 Install the bearings to the mast lower axle mounts.
- 3 Lubricate the bearing surfaces of the lower axle and tilt cylinder mounting brackets with chassis grease.
- 4 Lift the mast using an overhead hoist and lifting strap wrapped around the upright crossmembers. Position the mast lower axle mounts on the truck axle. Install the mount caps and capscrews. Tighten the capscrews to the truck manufacturer's torque specifications.

**IMPORTANT:** Prior to connecting the tilt cylinders to the mast, make sure the cylinders "bottom" evenly. Adjust the tilt cylinders to prevent the mast from "racking" during tilting. Refer to your truck service manual for procedures.

- 5 Connect the truck supply hose to the mast valve.
 

**NOTE:** Use as few fittings as possible. Always use 45° fittings instead of 90° fittings. Keep the hose length to a minimum. Avoid sharp bends or pinch points when routing the hose.
- 6 Connect the tilt cylinders to the mast anchor brackets. Tighten the pin capscrews to the truck manufacturer's torque specifications.
- 7 Check the oil level in the truck hydraulic tank when the mast is fully lowered. Fill if required.

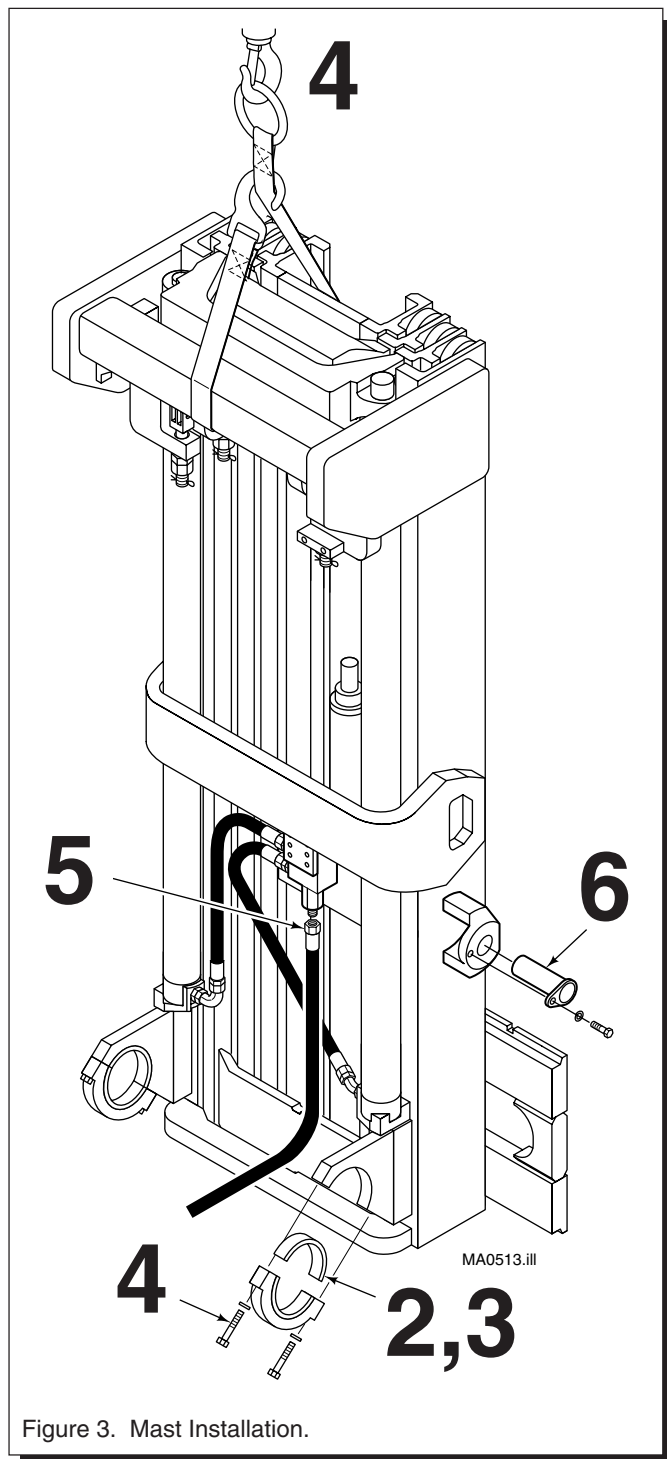

Figure 3. Mast Installation.

# Operational Inspection and Adjustments

**CAUTION:** The factory set adjustments may not be correct for your truck. Check each of the following before using the mast for the first time.

- Inspect the chains and check chain tension.
- Check the main lift chains for proper adjustment.
- Check the free lift chains for proper adjustment.

## Chain Inspection and Tension

The main and free lift chains have been factory lubricated using heat and pressure to force the lubricant thoroughly into the chain links. Avoid removal or contamination of this factory applied lubricant. **Do not wash, sand blast, etch, steam clean, or paint the chains for initial mast installation.**

The chains must be adjusted with equal tension to ensure proper load distribution and mast operation. To determine equal tension, extend the unloaded mast to put the chains under tension. Press the center of a strand of chain with your thumb. Then press at the same place on the other chain of the pair. Each chain in a pair should have equal “give”. If they do not have equal tension, perform the Main Lift and Free Lift chain adjustments described below.

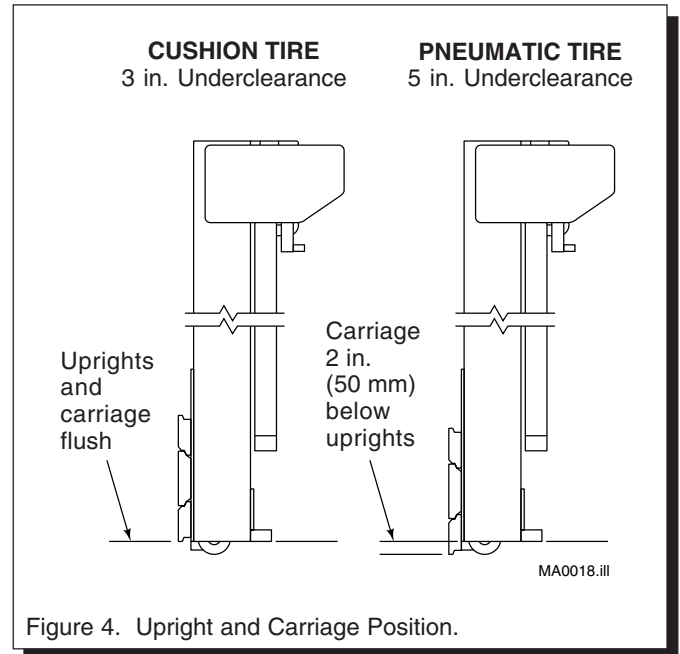

Figure 4. Upright and Carriage Position.

## Inner and Outer Main Lift Chain Adjustment

The main lift chains should be adjusted so that when the unloaded mast is fully lowered, the uprights are flush as shown in Figure 4.

- 1 Adjust one chain to achieve the correct carriage position when fully lowered, as shown in Figure 4 and 5.
- 2 Adjust the other chain to achieve equal chain tension. Tighten the nuts together to a torque of 50-70 ft.-lbs. (68-95 Nm).
- 3 Raise and lower the mast several times to confirm the adjustments.

## Free Lift Chain Adjustment

The free lift chains should be adjusted so that when the unloaded mast is fully lowered, the carriage is positioned as shown in Figure 4.

- 1 Locate the threaded chain anchors on the front side of the inner upright crossmember on each side of the cylinder.
- 2 Adjust one chain to achieve the correct upright and carriage position when lowered. See Figure 4 and 5.
- 3 Adjust the other chain to achieve equal chain tension. Tighten the nuts together to a torque of 50-70 ft.-lbs. (68-95 Nm).
- 4 Raise and lower the mast several times to confirm the adjustments.

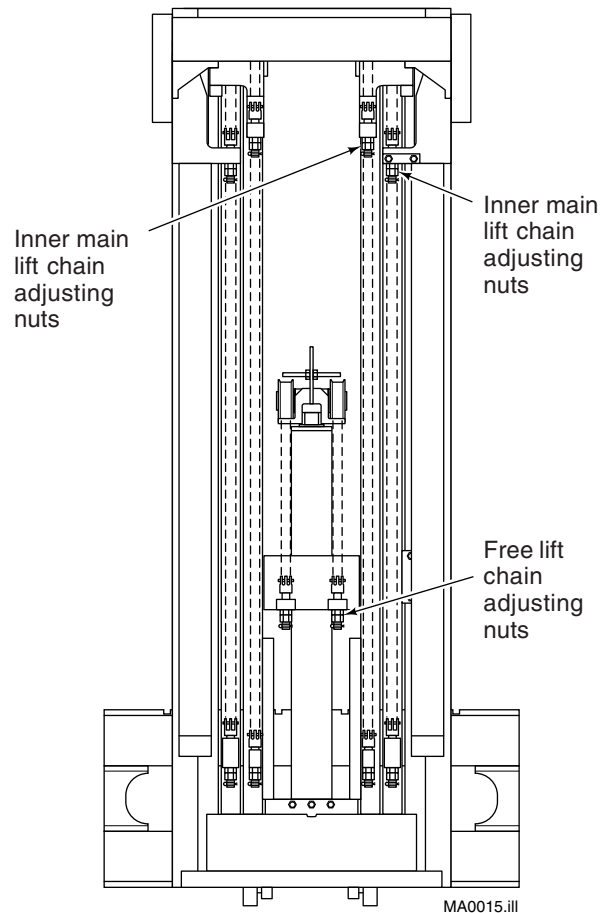

Figure 5. Chain adjustment.

# Operational Inspection and Adjustments (Continued)

## Upright Channel Lubrication

Lubricate the full length of each upright channel with chassis lube or Kendall SR-8X as shown. See Figure 6.

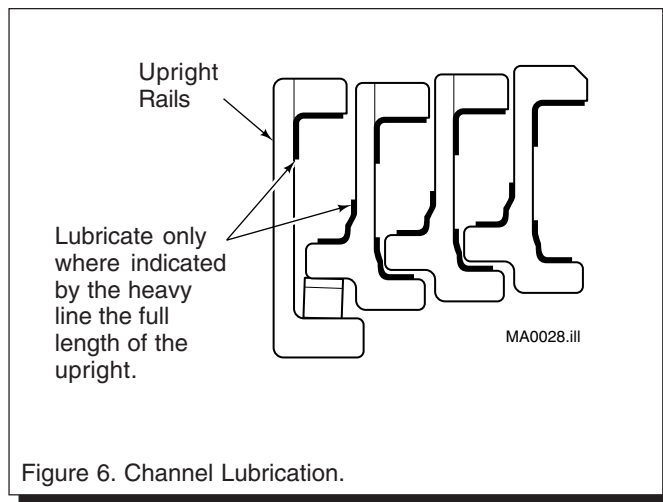

Figure 6. Channel Lubrication.

## Mast Skewing

- 1 Extend the mast to full lift height. See Figure 7.
  - If the mast bends to the right at full extension, a shim(s) need to be removed from the left main lift cylinder rod.
  - If the mast bends to the left at full extension, a shim(s) need to be installed to the left main lift cylinder rod.

**WARNING:** The upright must be supported by a block to avoid possible injury

- 2 Place a 20 in. (50 cm) long, 4 X 4 in. (10 X 10 cm) wood block between the outer intermediate and outer upright crossmembers. See Figure 8. Lower the mast onto the block.
- 3 Remove the snap ring from the left hand cylinder rod. Open the truck valve to allow the cylinder rod to retract. Tap the cylinder rod down past the crossmember. Install or remove shim(s) on the cylinder rod below the inner upright crossmember. See Figure 8. Shims are listed below.

Shim Thickness	Part No.
.010 in. (.25 mm)	205198
.031 in. (.79 mm)	205199
.062 in. (1.57 mm)	205196
.093 in. (2.36 mm)	205197

- 4 Repeat steps 1 through 3 until skewing is removed.

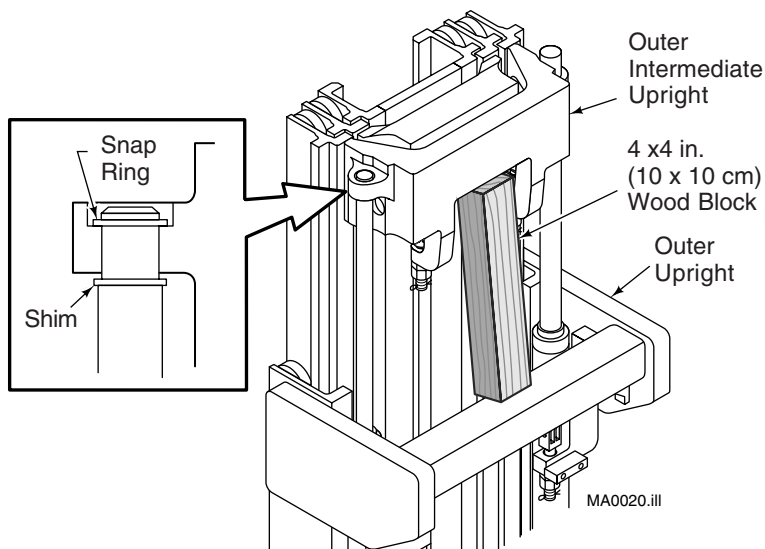

Figure 8. Extending Upright.

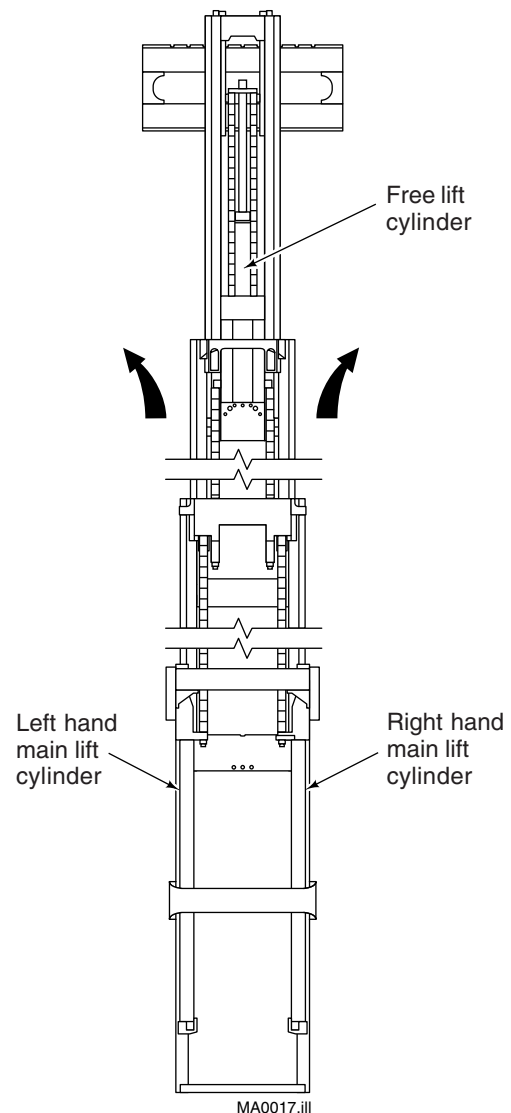

Figure 7. Extending upright viewed from driver seat.